

Compact hydraulic power pack type KA and KAW

Compact hydraulic power packs are a type of hydraulic power pack. They are characterised by a highly compact design, since the motor shaft of the electric motor also acts as the pump shaft.

The ready-for-connection compact hydraulic power pack type KA and KAW includes an electric motor which runs in oil. The stator is securely attached to the housing (tank). The compact hydraulic power pack is suitable for hydraulic systems with operating mode S2, S3 or S6. The heat is dissipated via surface convection so that no external cooler is usually necessary.

For systems with high loads, an external fan that enables additional heat dissipation can be optionally mounted on the housing. The fan is powered by a separate motor independently of the pump motor. Type KA includes a 3-phase motor, while type KAW includes a single-phase motor. The compact hydraulic power pack type KA and KAW is available in horizontal and vertical versions. Modules can be added to the tank so that different usable oil volumes are possible. Either single-circuit systems or dual-circuit systems can be selected. A radial piston pump or external gear pump can be used as a hydraulic pump. The compact hydraulic power pack type KA and KAW is suitable as a highly compact control system, since connection blocks and valve banks can be directly mounted.

Features and benefits:

- Additional separately driven fan for maximum utilisation of power
- Fill/usable volumes can be flexibly extended by modular tank extensions
- Long lifetime and excellent reliability achieved by using radial piston pumps
- Low oil fill volumes make it environmentally sound thanks to small amount of oil to be disposed of and low costs for hydraulic fluid
- Co-ordinated range of valves and accessories from modular system
- Suitable for vertical and horizontal installation
- Optimum efficiency thanks to suboil motor cooling, direct transmission of force and cleverly designed heat dissipation

Intended applications:

- Brake and rotor adjustment modules on wind turbines
- Clamping systems on machine tools and appliances
- Torque wrenches
- Rivets and clinching equipment
- Presses
- Handling systems



Nomenclature:	Radial piston or gear pump with integrated motor single or dual circuit pump
Design:	Oil immersed hydraulic power pack for intermittent or load/no load operation (S3-service)
p_{max}:	Radial piston pump 700 bar Gear pump 180 bar
Q_{max}:	Radial piston pump approx. 7 lpm (V _g = 2.29 cm ³ /rev) Gear pump approx. 24.1 lpm (V _g = 7.9 cm ³ /rev)
V_{tank max}:	2 ... 10 l

Design and order coding example

KA28	22	L1	KFTP	/HZ0,59/8,8	- ...	- 3x400V	- G1/2x300
							Oil drain hose
							Motor voltage 3 ~ 400V 50 Hz, 3 ~ 460V 60 Hz, 3 ~ 690V 50 Hz, 1 ~ 230V 50 Hz, 1 ~ 110V 60 Hz (1~phase motor)
							Valve design
			Pump version				Single circuit pump <ul style="list-style-type: none"> Radial piston pump H or gear pump Z Dual circuit pump <ul style="list-style-type: none"> with joint connection pedestal for pressure connections P1 and P3 Combinations: Radial piston pump - radial piston pump (HH) and radial piston pump - gear pump (HZ)
			Additional function				<ul style="list-style-type: none"> Oil sight glass Level gauge with level switch Temperature switch Silica gel filter (instead of breather filter) Additional fans Various electrical connection variants (type KA...S)
			Installation position				Horizontal version with low installation heights (type KA..L) or vertical version (type KA..S)
			Tank size [L]				
Basic type, size	Type KA (3~phase motor) and KAW (1~phase motor, power reduction 30 ... 50% dep. on size), size 2 and 4						

Function

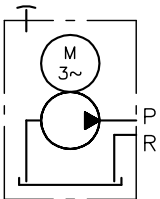

KA 231 LKP/H 0.59 - A1 D 10-B 400-3/380 - BA 2

- NBVP 16 G/R/AB 2.0 - M/O
 - NBVP 16 Y/ABR 1.5/4 - M/O
 - 1 - G 24

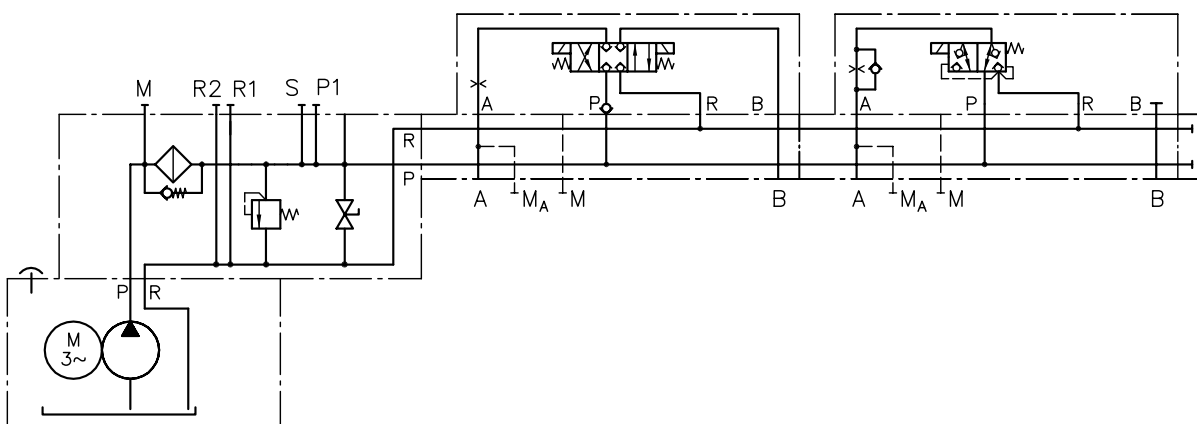

General parameters and dimensions

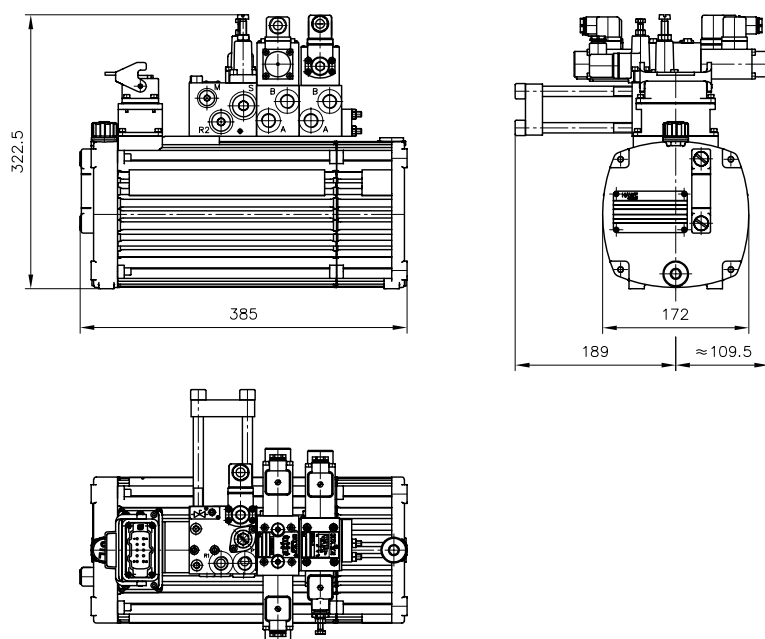

	3-cylinder radial piston pump			6-cylinder radial piston pump			Gear pump			P _N [kW]
	p _{max} [bar]	Q _{max} [lpm] 50 Hz	Q _{max} [lpm] 60 Hz	p _{max} [bar]	Q _{max} [lpm] 50 Hz	Q _{max} [lpm] 60 Hz	p _{max} [bar]	Q _{max} [lpm] 50 Hz	Q _{max} [lpm] 60 Hz	
KA 21	700 - 45	0,63 - 10,02	0,76 - 12,05	360 - 55	1,26 - 7,84	1,52 - 9,42	170 - 60	2,23 - 6,7	2,68 - 8,04	0,55
KA 22	700 - 140	0,63 - 0,02	0,76 - 12,05	700 - 180	1,26 - 7,84	1,52 - 9,42	170 - 55	2,23 - 22,04	2,68 - 26,47	1,1
KA 23	700 - 60	0,31 - 4,89	0,37 - 5,93	485 - 30	0,62 - 9,79	0,75 - 11,85	170 - 50	1,09 - 4,90	1,32 - 5,94	0,37
KA 24	700 - 160	0,31 - 4,89	0,37 - 5,93	700 - 80	0,62 - 9,79	0,75 - 11,85	170 - 65	1,09 - 10,74	1,32 - 13,04	0,75
KA 26	700 - 160	0,63 - 10,02	0,76 - 12,05	700 - 205	1,26 - 7,84	1,52 - 9,42	170 - 65	2,23 - 22,04	2,68 - 26,47	1,4
KA 28	700 - 185	0,31 - 4,89	0,37 - 5,93	700 - 90	0,62 - 9,79	0,75 - 11,85	170 - 75	1,09 - 10,74	1,32 - 13,04	1,0

	3-cylinder radial piston pump			6-cylinder radial piston pump			Gear pump			P _N [kW]
	p _{max} [bar]	Q _{max} [lpm] 50 Hz	Q _{max} [lpm] 60 Hz	p _{max} [bar]	Q _{max} [lpm] 50 Hz	Q _{max} [lpm] 60 Hz	p _{max} [bar]	Q _{max} [lpm] 50 Hz	Q _{max} [lpm] 60 Hz	
KA 42	700 - 220	0.84 - 11.8	2.0 - 14.4	700 - 110	3.3 - 23.8	4.0 - 28.9	200 - 130	1.6 - 18.0	2.0 - 22.0	- 2.6 - 3.9
KA 44	700 - 220	1.6 - 5.98	1,01 - 7,25	700 - 110	1,68 - 11,97	2,04 - 14,53	200 - 130	0,84 - 9,1	1,01 - 11,1	- 1,5 - 2,2 - 3,0

Example circuit:

KA 281 S16K/H3.61-FSHS-24VDC -A 14/230
-BVH 11 W/CZ52/117GM/B3,5H
-82 - AC1002/130/3A
-XM 24
3x400V 50Hz

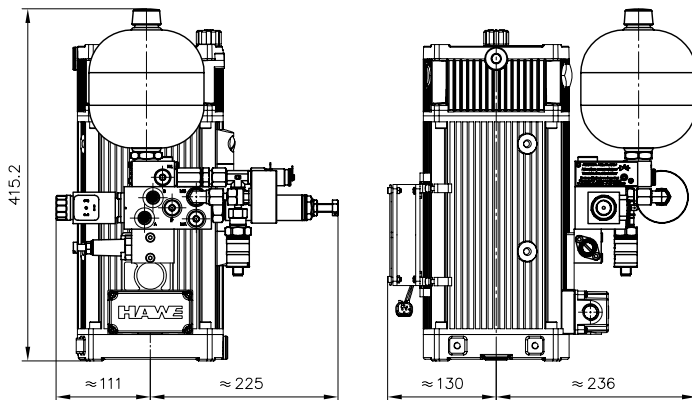
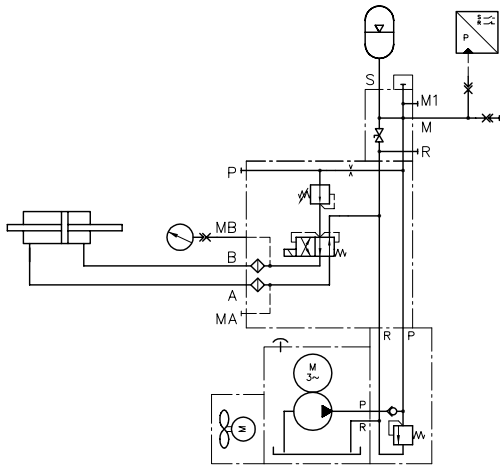

Associated technical data sheets:

- Type KA compact hydraulic power packs:
[D 8010](#), [D 8010-4](#)

Similar products:

- Compact hydraulic power pack type HCG:
[D 7900 G](#)

Suitable connection blocks:

- Types A, B and C: [D 6905 A/1](#), [D 6905 B](#),
[D 6905 C](#)

Directly mountable valve banks:

- Lifting/lowering valve type HSV: [D 7032](#)
- Valve bank (directional seated valve) type
BWN and BWH: [D 7470 B/1](#)
- Types SWR, SWS: [D 7451D 7951](#)
- Valve bank (nominal size 6) type BA:
[D 7788](#)
- Valve bank (directional seated valve) type
BVH: [D 7788 BV](#)