

Radial piston pump type R, RG and RZ

Radial piston pumps are a type of hydraulic pump. They consist of valve-controlled pump cylinders that are arranged radially.

The radial piston pump type R, RG and RZ has a closed pump housing. Therefore, besides use as a motor pump outside an oil tank, installation in the container of a hydraulic power pack is also possible. The radial piston pump is available with several pressure outlets which enable the same or several different volumetric flows. Type RZ is a classic dual-stage pump consisting of a radial piston pump and a gear pump. The radial piston pump type RG has plain bearings which have a longer storage life. This type is therefore used in extreme operating conditions.

Extremely high volumetric flows can be achieved by arranging up to 6 radials in parallel. When the radial piston pump is used in the hydraulic power pack, it is suitable for use as a highly compact control system. Connection blocks and valve banks can be mounted on the cover plate of the hydraulic power packs.

Features and benefits:

- High level of efficiency
- Compact design
- Max. 14 separate pressure outlets
- Available from the modular product range as a hydraulic power pack with valve banks

Intended applications:

- Press construction
- Jig construction
- Testing and laboratory devices
- Lubricating systems



Nomenclature:	Radial piston pump
Design:	Single pump ; dual-stage pump
p_{max}:	700 bar
Q_{max}:	91.2 lpm (V _g = 64.18 cm ³ /rev)

Design and order coding example

RZ 0,9 / 2 - 16

Sizes Delivery flow gear pump [lpm]

Basic type, delivery flow [lpm]

- Type R (version with roller bearing)
- Type RG (version with plain bearing)
- Type RZ (dual-stage pump)

Additional versions:

- With several pressure ports
- With separate ports for the flow of one or two pump elements (Q_{max} = 4,4 lpm)
e.g. as control oil supply

Function

Single pump type R and RG

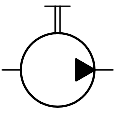

Single pump type RZ
only high-pressure section,
low-pressure section is
installed by customer

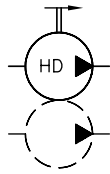

Single pump type RZ
High and low-pressure section

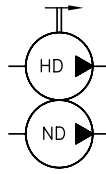

Pump with several pressure
outlets (example for an Single
pump)

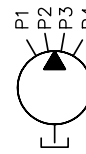

General parameters and dimensions

Single pump type R and RG

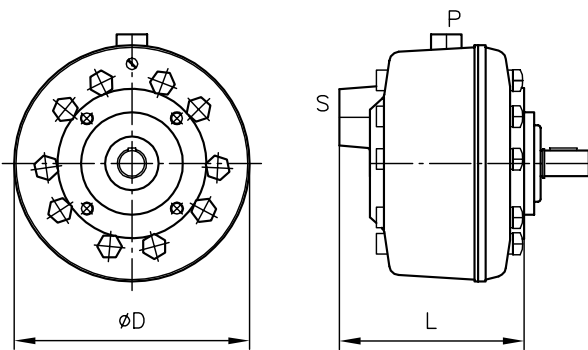

Single pump type RZ

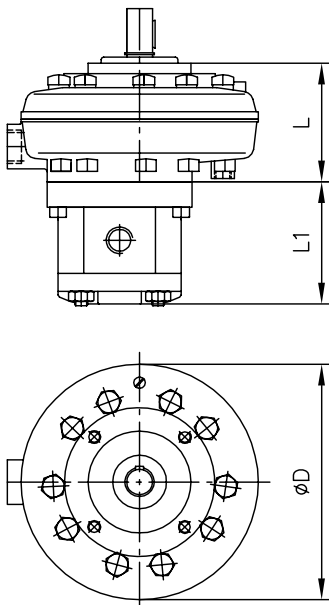

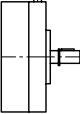
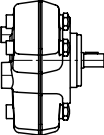
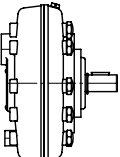
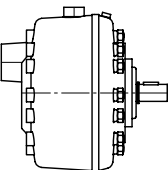
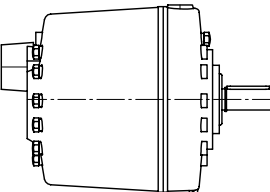
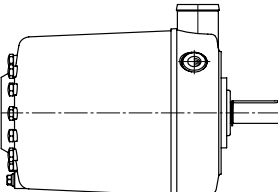
Design	Number of cylinders	Delivery flow Q_{pu} (lpm) (approximate reference value at 1450 rpm) and max. pressure p_{max} (bar)						P_N [kW]	Dimensions [mm]		
		700 bar	550 bar	450 bar	250 bar	160 bar	D		L	m [kg]	
7631 	2	0.18	0.28	0.43	0.92	-	0.25...0.55	130	53/58	3.2	
	3	0.27	0.42	0.64	1.35	-					
	5	0.46	0.7	1.08	2.27	-					
6010/ 6910 	1	0.3	0.5	0.8	1.7	2.2	0.25...3	174	82.5/85.5	3.1	
	2	0.6	1.0	1.6	3.3	4.4					
	3	0.9	1.5	2.5	5.1	6.5					
6011/ 6911 	5	1.4	2.6	4.2	8.3	10.9	0.55...5.5	185	86/85	5.8	
	7	2.1	3.7	5.8	11.8	15.3					
6012/ 6912 	10	2.7	5.3	8.2	16.8	21.7	2.2...11	185	146/125	10.5	
	14	4.0	7.4	11.6	23.5	30.4					
6014/ 6914 	20	6.1	11.0	17.4	35.0	43.4	5.5...22	218	250/221	24.2	
	28	8.0	15.0	23.0	47.0	60.8					
6016/ 6916 	42	12.7	22.0	34.5	70.0	91.2	11...30	238	311/320	39.1	

- The data listed represent only a selection of the various different versions
 1) Standard motor, design IM B 35 for motor pumps or IM B 5 for hydraulic power packs

Gear pump

Size	Delivery flow Q_{pu} [lpm] and max. pressure p_{max} [bar]			Dimensions [mm]	m [kg]
	120 bar	80 bar	40 ... 60 bar		
/1	5,2	8,8	11,3	70 ... 86	1,2
/2	12,3	16	37	96 ... 132	3,1
/3	24	110	135	140 ... 178	8,4

- The data listed represent only a selection of the various different versions

Circuit example:

R 4,0/B 50 A 700 - VB 11 DM - HRHR - 1 - G 24 - V 5,5

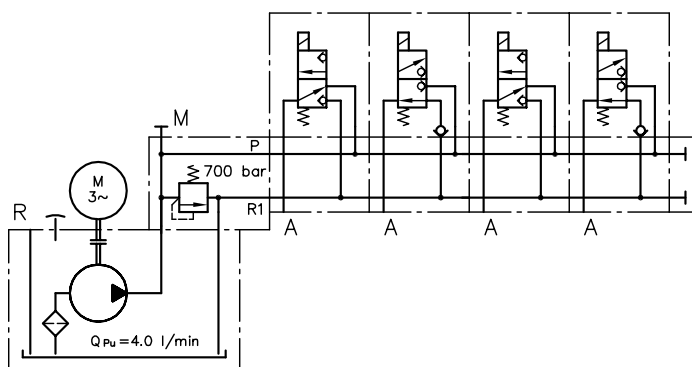
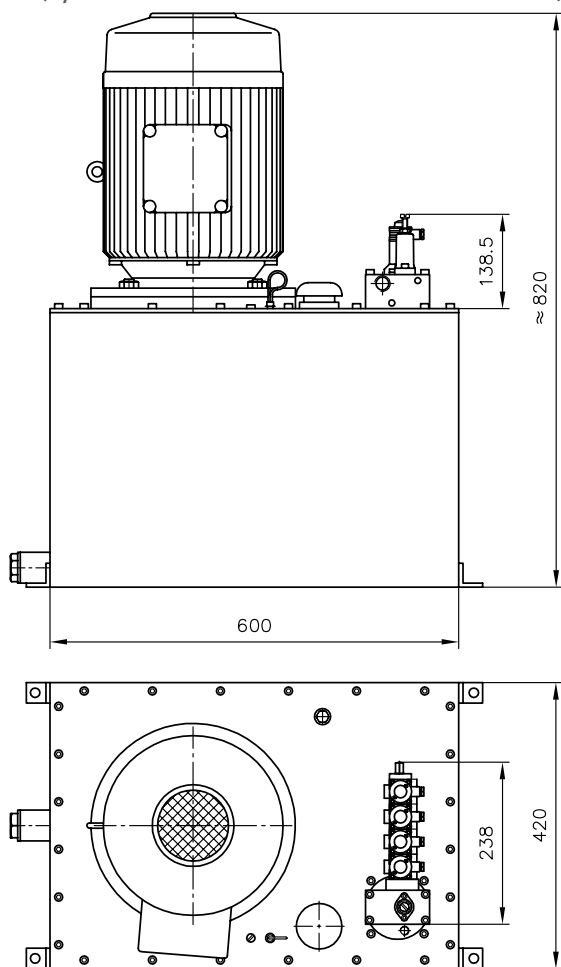

Associated technical data sheets:

- [Radial piston pump type R and RG: D 6010](#)
- [Motor pump and hydraulic power pack type R and RG: D 6010 H](#)
- [Radial piston pumps with several pressure connections type R, RG: D 6010 D, D 6010 DB](#)
- [Radial piston pump type R and RG with one main pressure connection and one or two ancillary pressure connections: D 6010 S](#)

Directly mountable valve banks:

- [Valve bank \(directional seated valve\) type VB: D 7302](#)
- [Valve bank \(directional seated valve\) type BWN and BWH: D 7470 B/1](#)
- [Directional spool valve type SW: D 7451](#)